

# EL PELIGRO

*Pinta las acciones que son un peligro para los niños.*

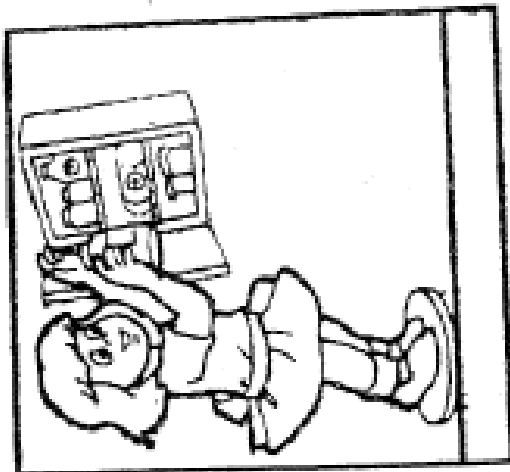
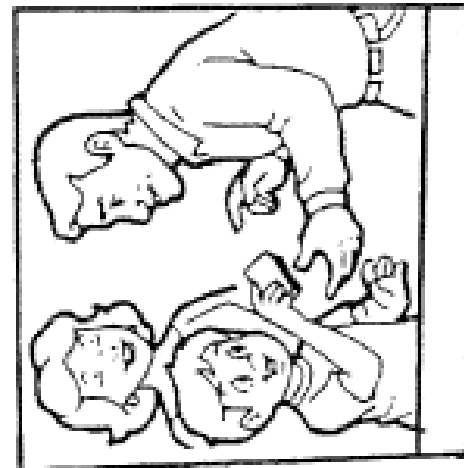
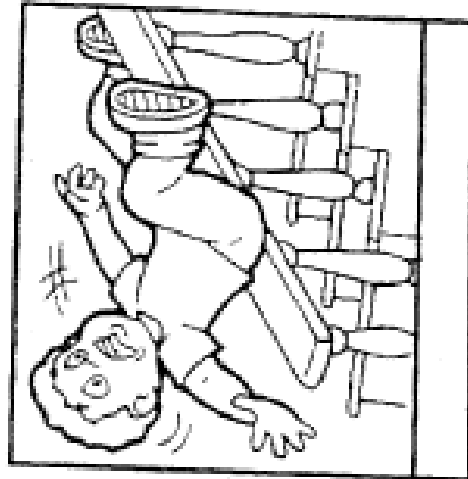

- Lo que nos puede quemar.

*Pinta los elementos que pueden causar quemaduras en nuestro cuerpo.*

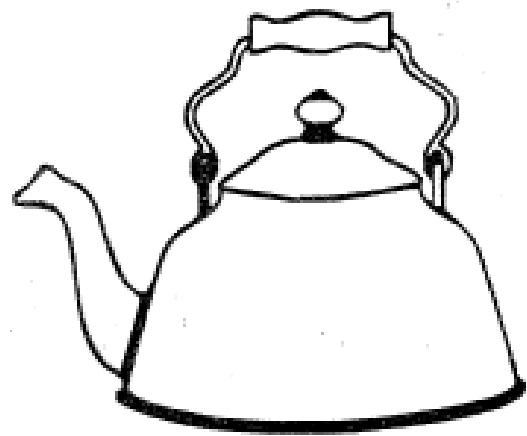
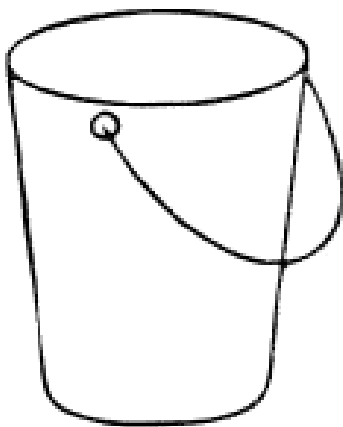
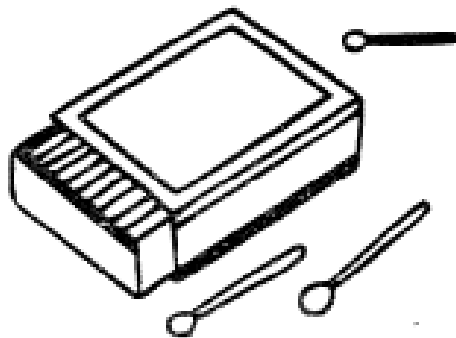
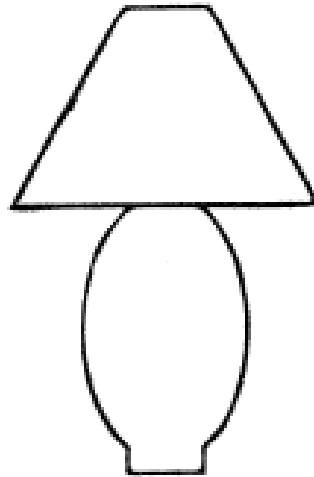
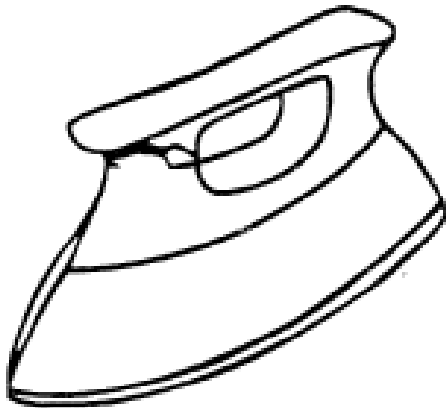

- Elementos punzo cortantes.

*Pinta los objetos que nos puedan dañar nuestro cuerpo.*

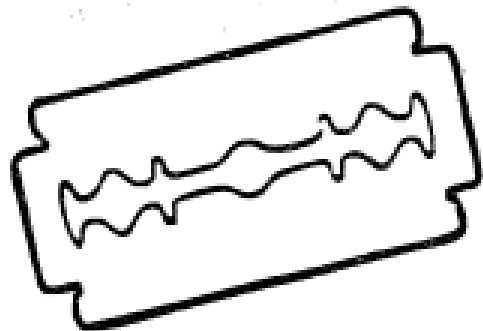
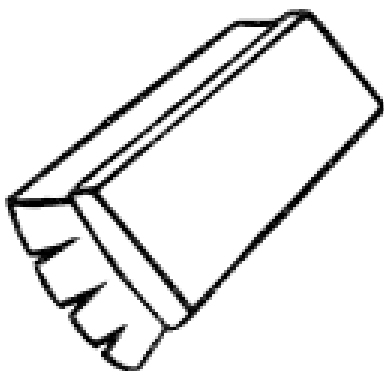
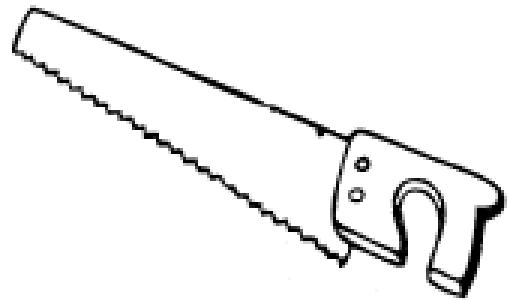
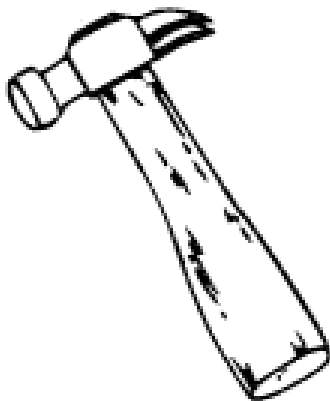
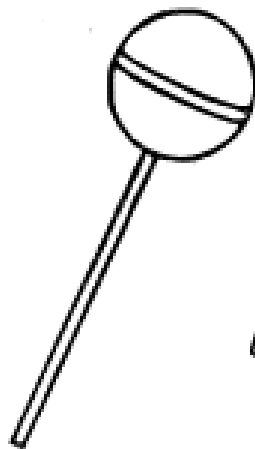
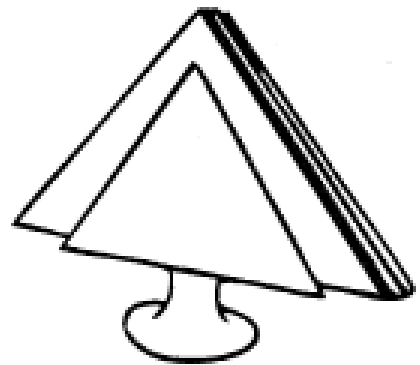
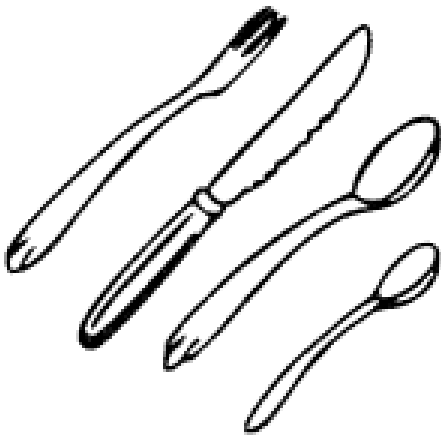

- **Sustancias peligrosas.**

*Pinta loas sustancias peligrosas que conoces que pueden causarte mucho daño.*

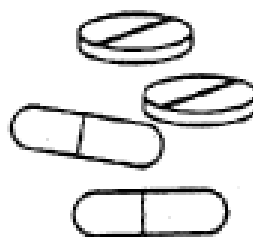
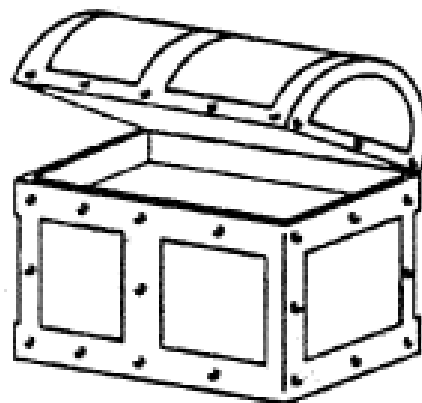
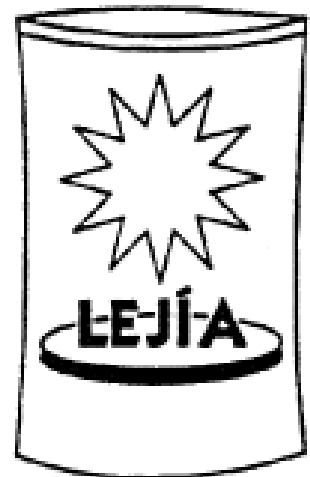
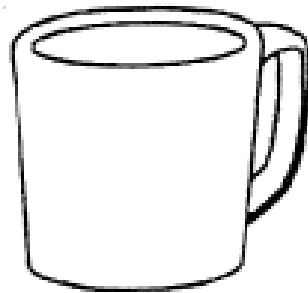

- Yo se cuidarme

*Comenta lo que significa cada escena que observas en esta ficha.*



No juego con la basura.

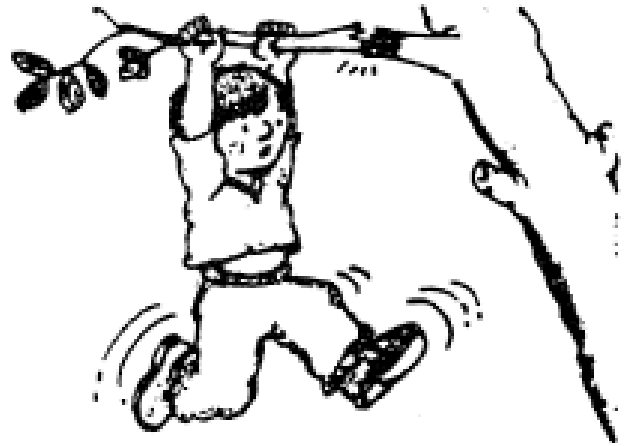

No me trepo a los arboles.



No abro frascos de medicinas.



Me cuido de las quemaduras.



No duermo con mis mascotas ni les doy besos.



No recojo del suelo las golosinas que se me han caído.