

MIS TRAZOS OBLICUOS

- Realiza trazos oblicuos correctamente colorea al rey libremente.

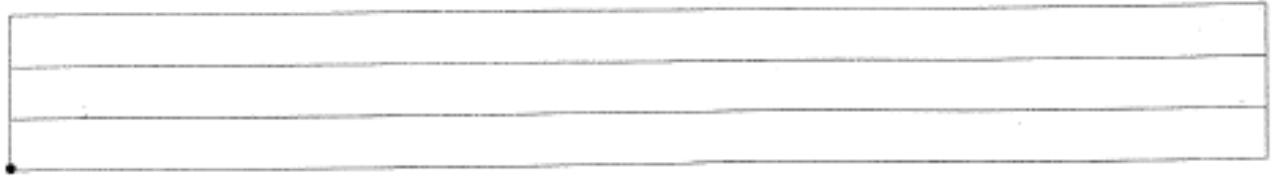

- *Repasa las líneas punteadas y completa el dibujo.*

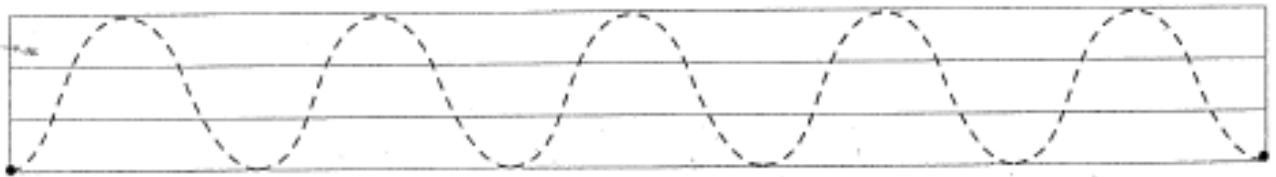
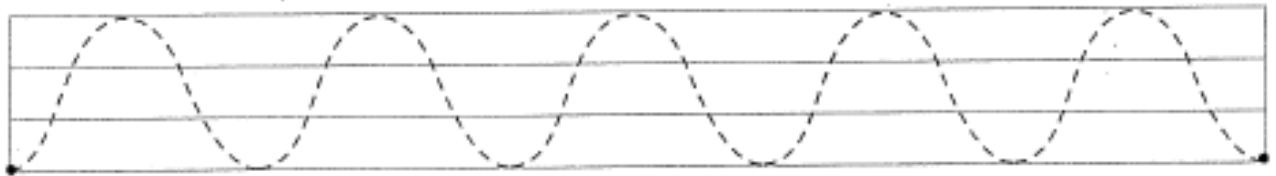
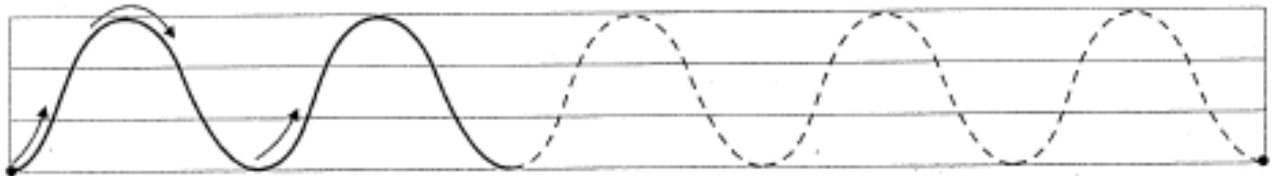
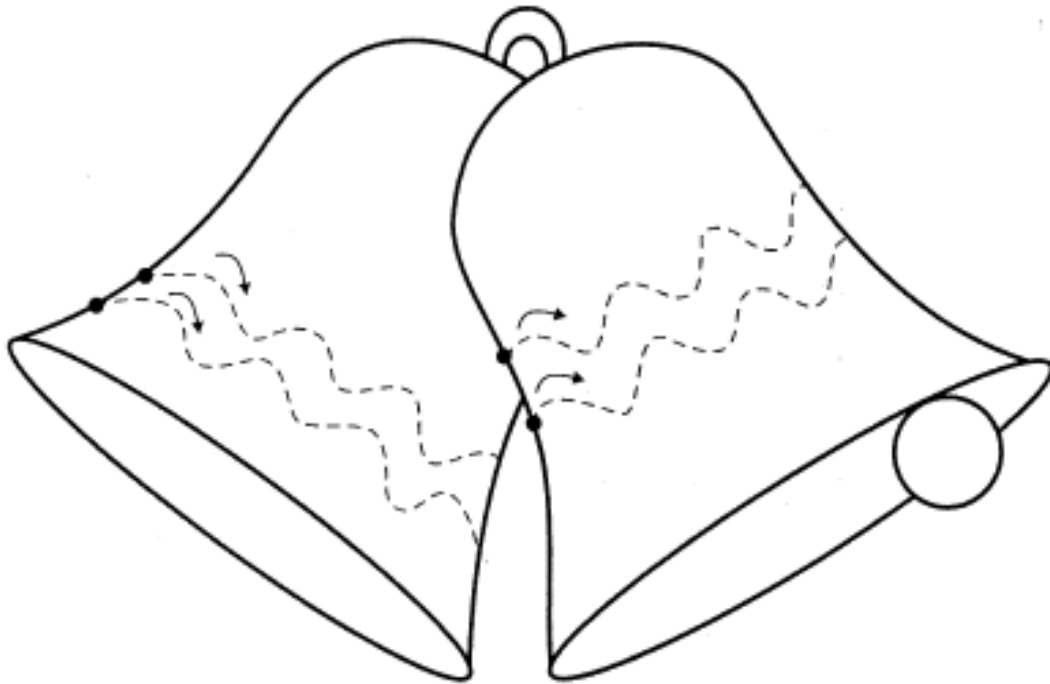

Trazos oblicuos

- *Traza con tu crayola las líneas entrecortadas, respeta la dirección de las flechas.*

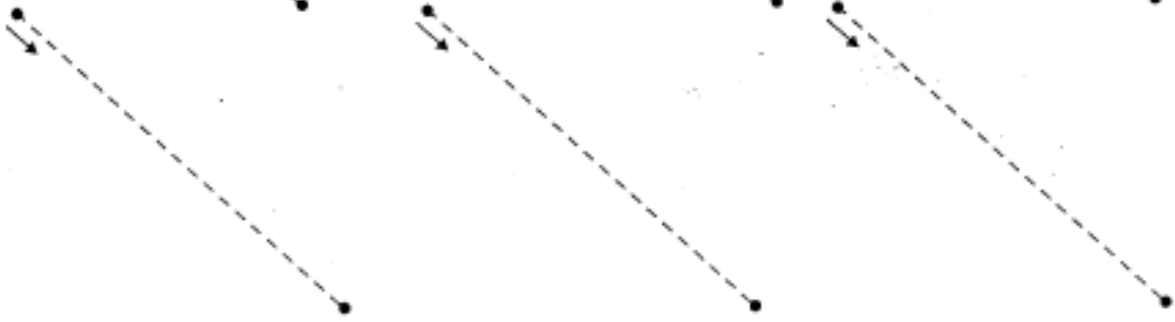
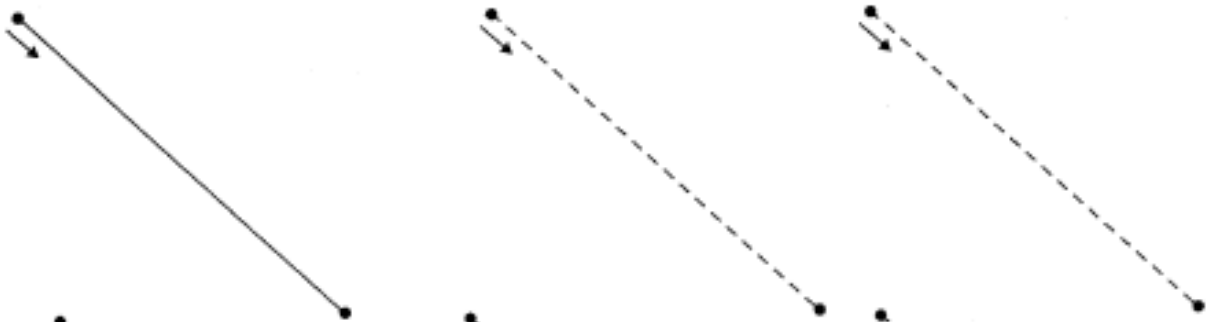
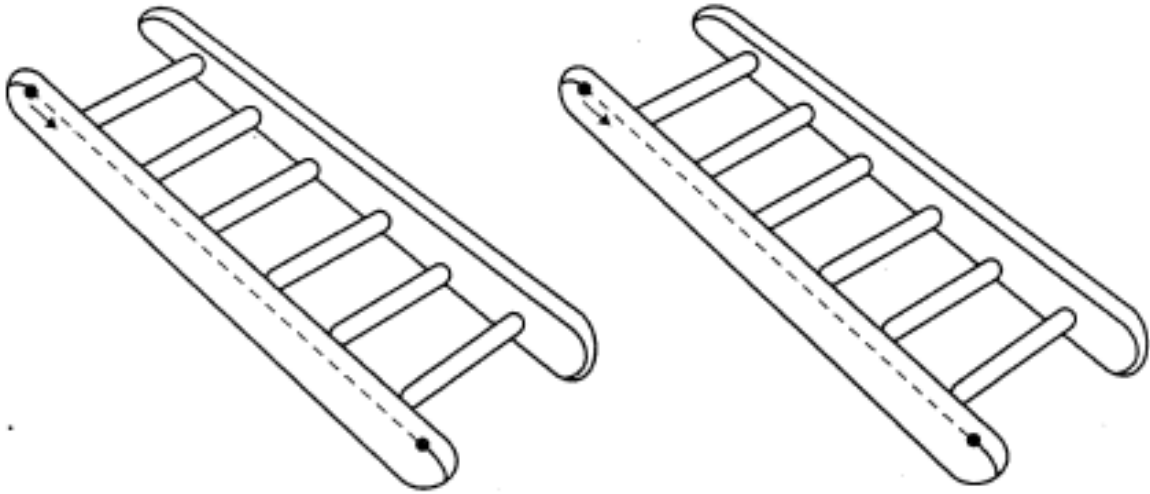

- *Traza las líneas oblicuas en dirección de las flechas, completa las que faltan.*

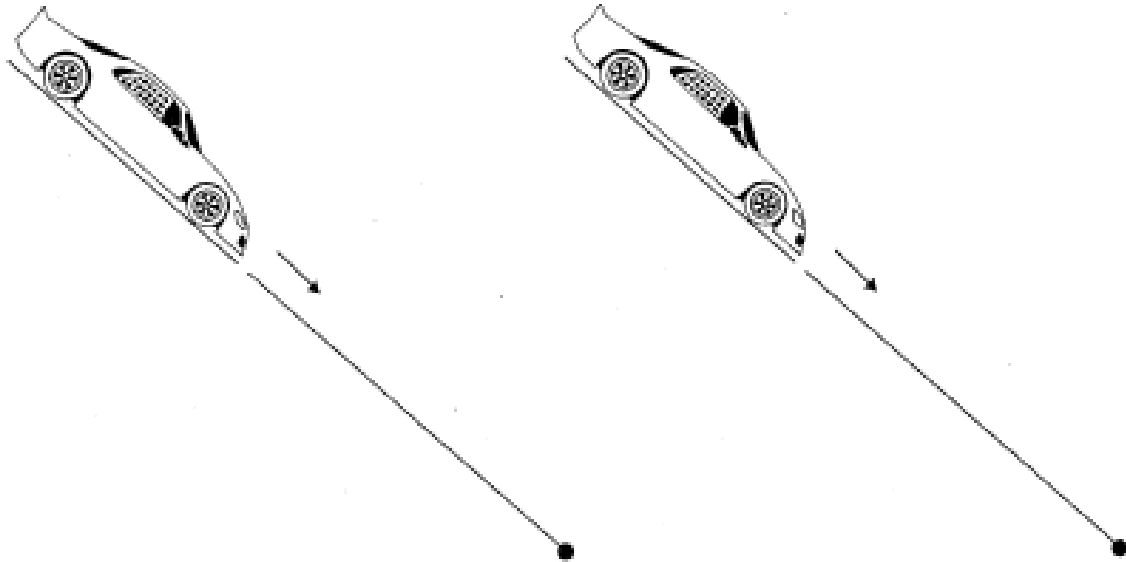

Trazos oblicuos

- *Sigue las líneas oblicuas en forma ascendente.*

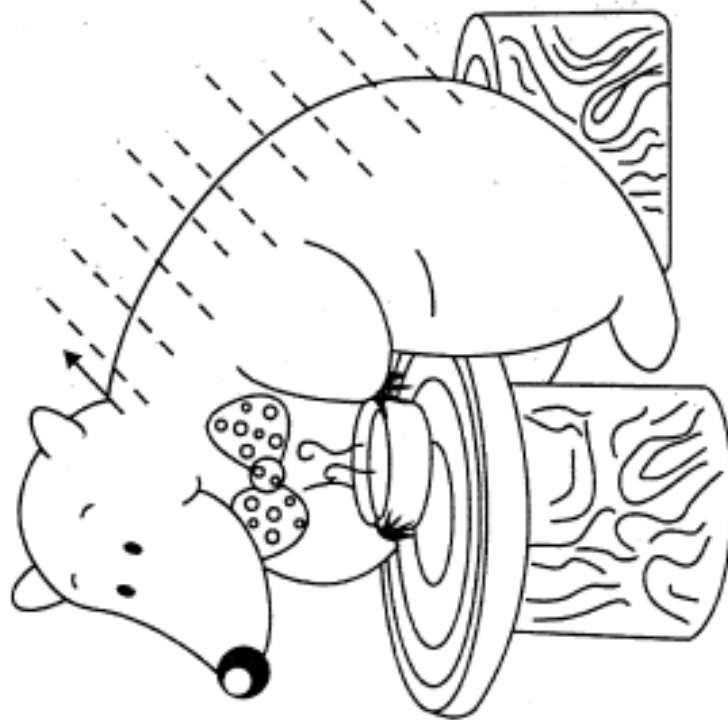
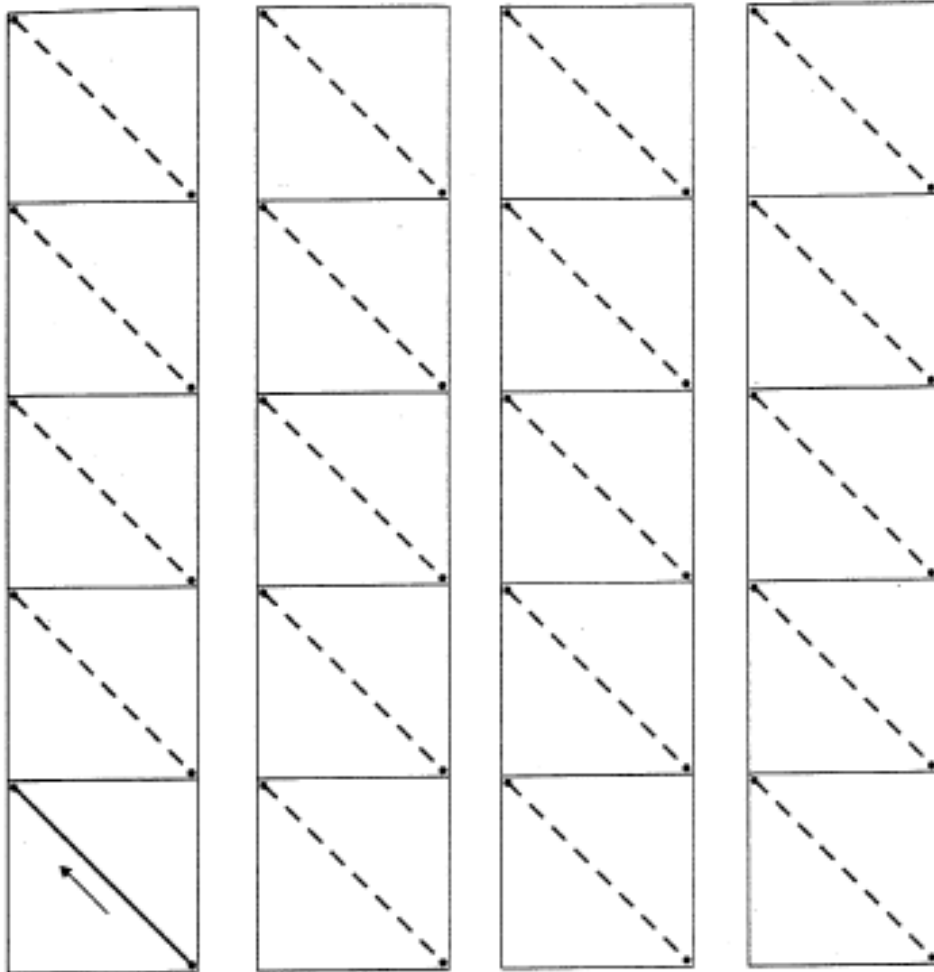

- *Sigue las líneas oblicuas de forma descendente.*

